



# FUTURE GURUKULS

*A Step Towards Future*

# AI & ROBOTICS HAND BOOK





## Class 5

SUBROTO CHATTERJEE

(AI & ROBOTICS TRAINER)

FUTURE GURUKULS EDUTECH PRIVATE LIMITED.

### IMPORTANT LINKS:

-  <https://www.futuregurukuls.in>
-  <https://in.linkedin.com/company/futuregurukuls>
-  <https://www.instagram.com/futuregurukuls>
-  <https://www.youtube.com/@futuregurukuls>
-  <https://kitvit.in>

## ACKNOWLEDGEMENT

I am deeply grateful and honored to present this *AI & Robotics Handbook* designed for students from Class 4 to 12. As a first-time author, this book represents not only my professional experience but also my passion for empowering young minds with practical knowledge in Artificial Intelligence, Robotics, IoT, and emerging technologies.

I sincerely thank **Future Gurukuls Edutech Private Limited** for providing me with the opportunity, platform, and continuous support to develop this comprehensive STEM learning resource. Their vision of delivering quality technical education to students has been a constant source of inspiration throughout this journey.

I also extend my heartfelt gratitude to my students, whose curiosity, enthusiasm, and innovative ideas motivated me to structure this handbook in a simple, practical, and activity-based format. Their questions and creativity helped shape the clarity and approach of this content.

Special appreciation goes to my mentors, colleagues, and well-wishers who encouraged me to take this step as a new author and guided me during the preparation of this handbook.

This book is a sincere effort to make AI and Robotics education accessible, practical, and engaging for school students. I hope it inspires learners to explore, experiment, and innovate in the field of technology.

**Subroto Chatterjee**

AI & Robotics Trainer

Future Gurukuls Edutech Private Limited

## INTRODUCTION

### IMPORTANT DEFINITION

(COMMON FOR ALL CLASS)

#### 1- What is a Robot?

Robot is a **smart machine** which can **take decision**, it works like a human and makes our works easier.

#### 2- What is IoT?

IoT Stands for *Internet Of Things*.

Connecting objects with internet and controlling it from anywhere around the world is called IoT.

#### 3- What is Computer programming?

Set of instructions or command by which we can communicate with computer, machine or robot is called programming.

There are various types of programming languages like **C, C++, JAVA, Python, Scratch, Arduino etc.**

#### 4- What is programming language?

A programming language is a vocabulary and set of grammatical rules for instructing a computer or computing device to perform specific tasks.

**Example - C, C++, C#, Arduino, Java, Python, Scratch, Cobol etc.**

#### 5- What is Input Device?

Such device which collects data from outside and send it inside of any brain, are called input devices.

**Ex- IR Sensor, LDR Sensor, Flame Sensor, Ultrasonic Sensor etc.**

Basically, all types of sensors are input devices.

#### 6- What are output devices?

Such devices which execute the final task according to the given input or give the final result, we called them output devices.

**Ex- LED Module, Buzzer, DC Motor, Servo Motor etc.**

## 7- What are Sensors?

**Sensors** are the sensing device *which detect any change in environment* and send signals to the microcontroller.

**Ex-** IR Sensor, LDR Sensor, Flame Sensor, Ultrasonic Sensor etc.

Basically, all types of sensors are input devices.

## 8- What are Actuators?

**Actuators** are the electronic device *which makes any change in environment* by signals from microcontroller.

**Ex-** LED Module, Buzzer, DC Motor, Servo Motor etc.

Basically, all types of sensors are Output devices.

## 9- What is Microcontroller?

A **Microcontroller** is a small computer on a single chip that is used to *control devices and machines*. It has a **processor, memory, and input/output pins** inside one chip.

**Ex-** Arduino, ESP8266 / ESP32, Raspberry Pi etc.

## 10- What is AI?

AI Stands for *Artificial Intelligence* Machines That Think

AI means *making machines smart* so they can *think and learn like humans*. It helps computers and robots to *learn from data and past experiences*. AI can see patterns, make decisions, and understand language.

**ACTIVITIES FOR CLASS 5**

<b>ACTIVITIES:</b>	<b>CURRICULUM ACTIVITIES</b>	<b>PAGE</b>
ACTIVITY 1:	Robot and the Role of Sensors	6
ACTIVITY 2:	Fire Detecting Car	7
ACTIVITY 3:	Obstacle Detecting Car	8
ACTIVITY 4:	Smart Solar Tracking System	9
ACTIVITY 5:	Learn to Fly a Drone	10
ACTIVITY 6:	Scratch Programming – Advanced Game Logic	12
<b>ACTIVITIES:</b>	<b>EXTRA ACTIVITIES</b>	<b>PAGE</b>
ACTIVITY 1:	Simple Study Lamp	
ACTIVITY 2:	Automatic Night Lamp	
ACTIVITY 3:	Simple Robotic Car	
ACTIVITY 4:	Light Follower Car	
ACTIVITY 5:	Spy Robot	
ACTIVITY 6:	Don't Touch Me Robot	

# ACTIVITY 1

## Robot and the Role of Sensors

### WHAT ARE SENSORS?

*A sensor is like a robot's eyes, ears, or nose. It helps a robot "feel" what's happening around it!*

#### Example:

- Eyes = See light
- Ears = Hear sound
- Nose = Smell smoke or fire

### Types of Sensors

- **LDR Sensor (Light Dependent Resistor)**

*It tells the robot if it's bright or dark.*

**Example:** Street lights turning on when it's dark

- **IR (Infrared) Sensor**

*It tells the robot if something is nearby.*

**Example:** Robot stops when your hand comes close

- **Flame Sensor**

*It smells fire or smoke so robots can stay safe.*

**Example:** Fire alarm sensor at home

### What's Common in All Sensors?

They all:

- Detect something (light, fire, or objects)
- Send signals to the robot's brain
- Help the robot decide what to do next

## ACTIVITY 2

### Fire Detecting Car

#### REQUIRED COMPONENTS:

1. Car Frame
2. Wheels
3. Castor Wheel
4. Screw & Nuts
5. Geared Motors
6. Motor Driver L298D
7. Power Board
8. 0-PIN Jumper Wire
9. Rechargeable Battery
10. Flame Sensor

**Diagram of Motor Driver**

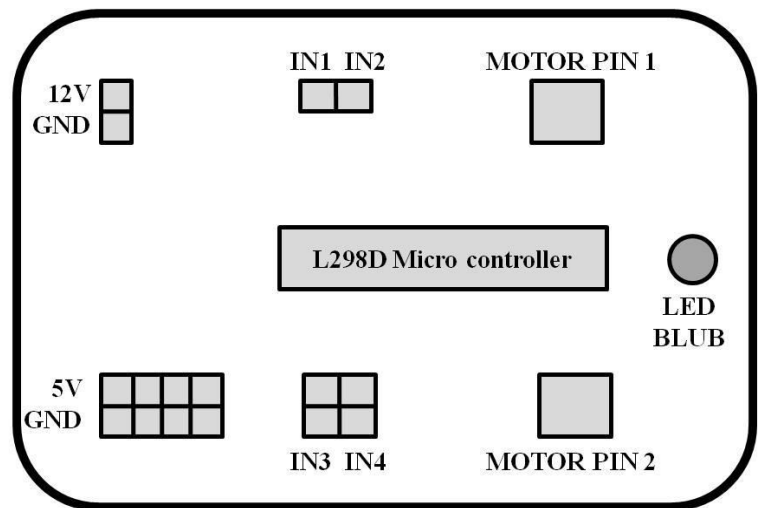

#### CONNECTION DIAGRAM:

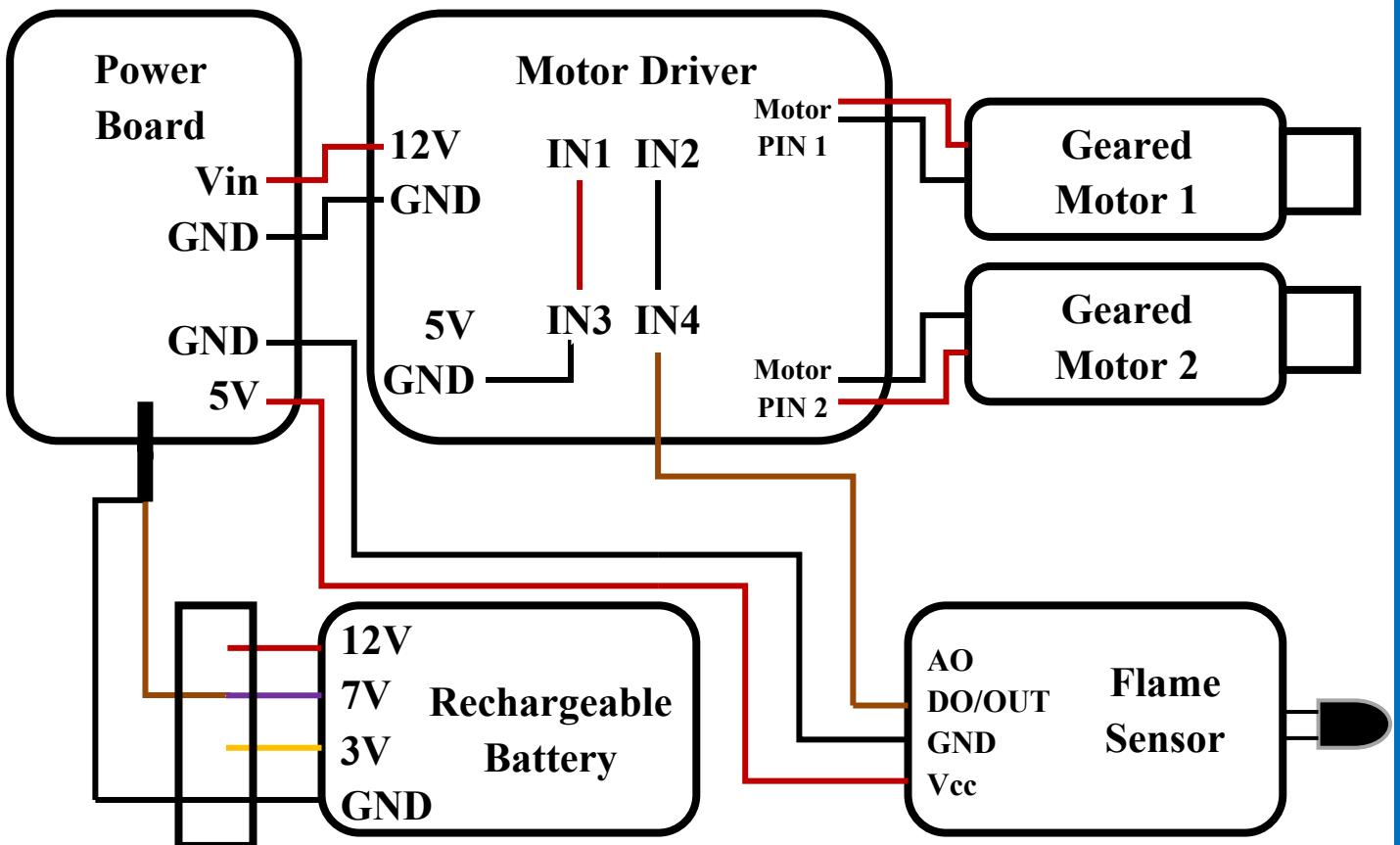

## ACTIVITY 3

### Obstacle Detecting Car

#### REQUIRED COMPONENTS:

1. Car Frame
2. Wheels
3. Castor Wheel
4. Screw & Nuts
5. Geared Motors
6. Motor Driver L293D
7. Power Board
8. 0-PIN Jumper Wire
9. Rechargeable Battery
10. IR Sensor

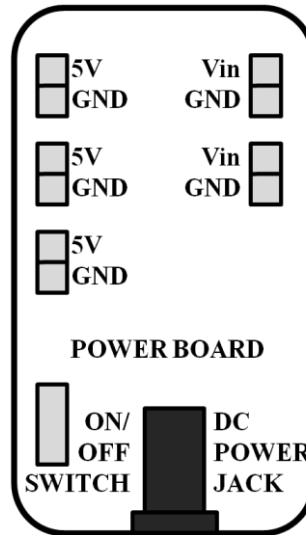

#### CONNECTION DIAGRAM:

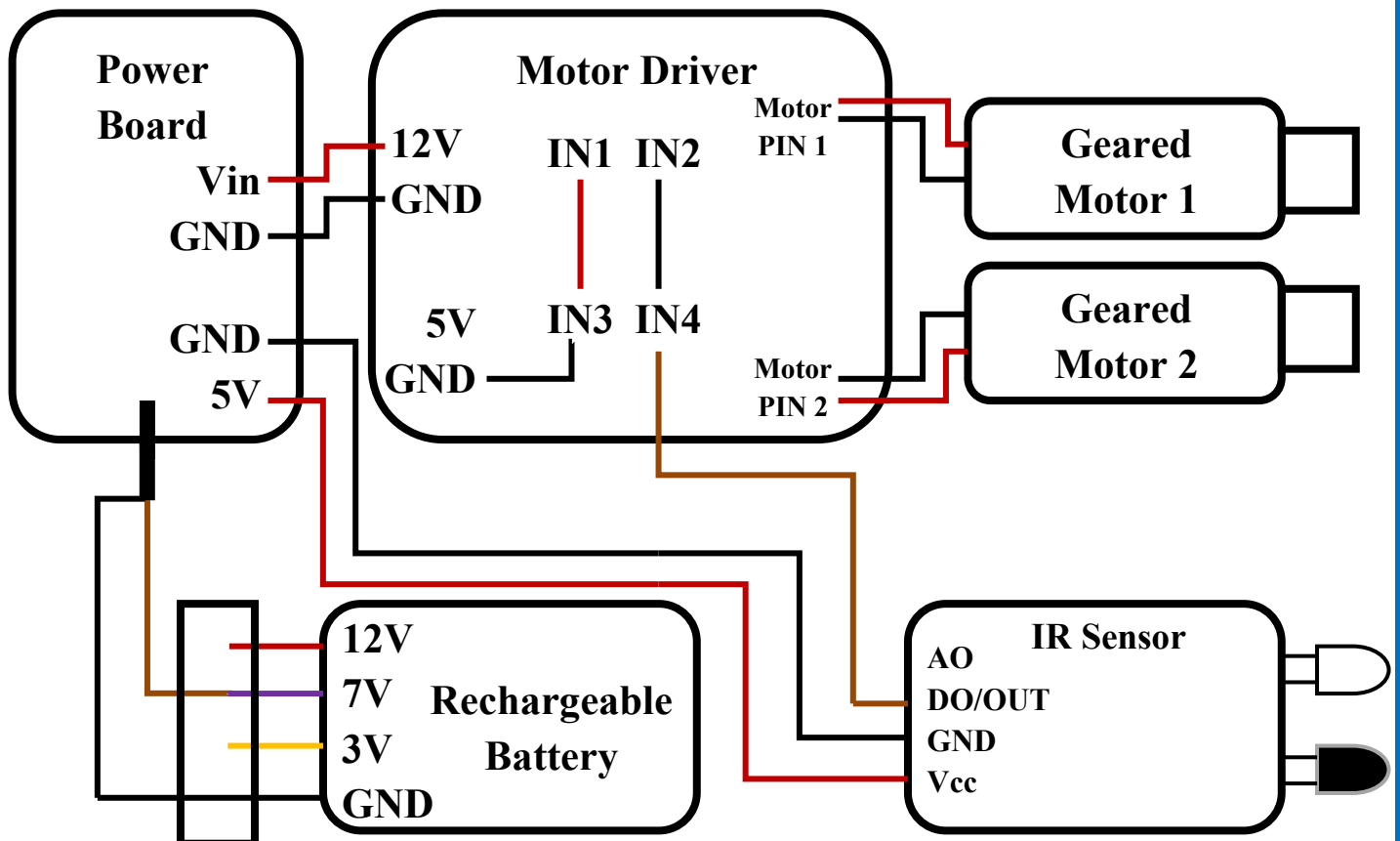

## ACTIVITY 4

### Smart Solar Tracking System

#### REQUIRED COMPONENTS:

1. Wheels
2. Geared Motors
3. Motor Driver L298D
4. Power Board
5. 0-PIN Jumper Wire
6. Rechargeable Battery
7. LDR Sensor

#### CONNECTION DIAGRAM:

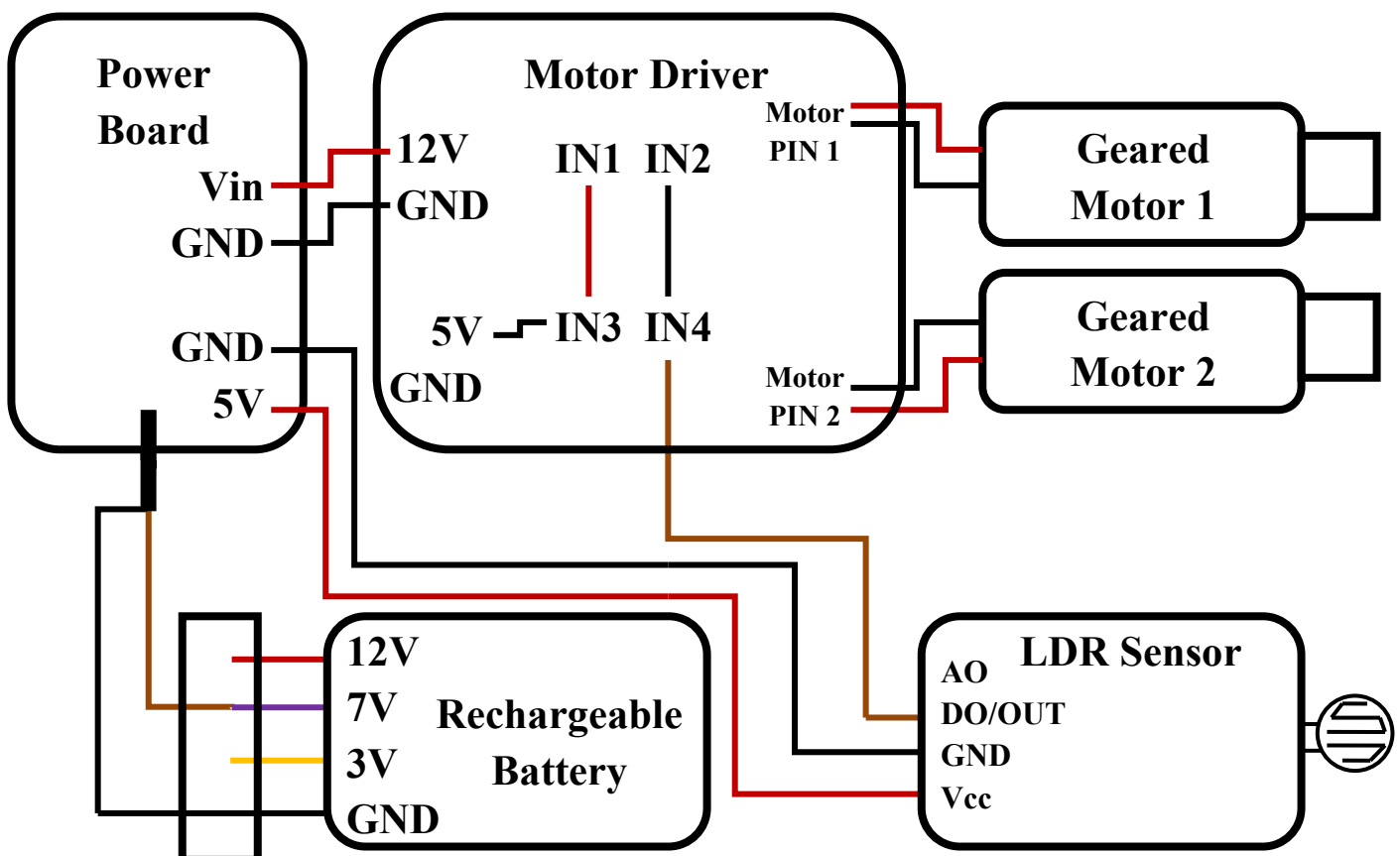

## ACTIVITY 5

### Learn to Fly a Drone

#### 1. How Does a Drone Fly?

A drone is made up of different parts. Each part works together to help the drone fly smoothly in the sky.

#### 2. Main Parts of a Drone

There are four most important parts of a drone:

### Main Parts of a Drone

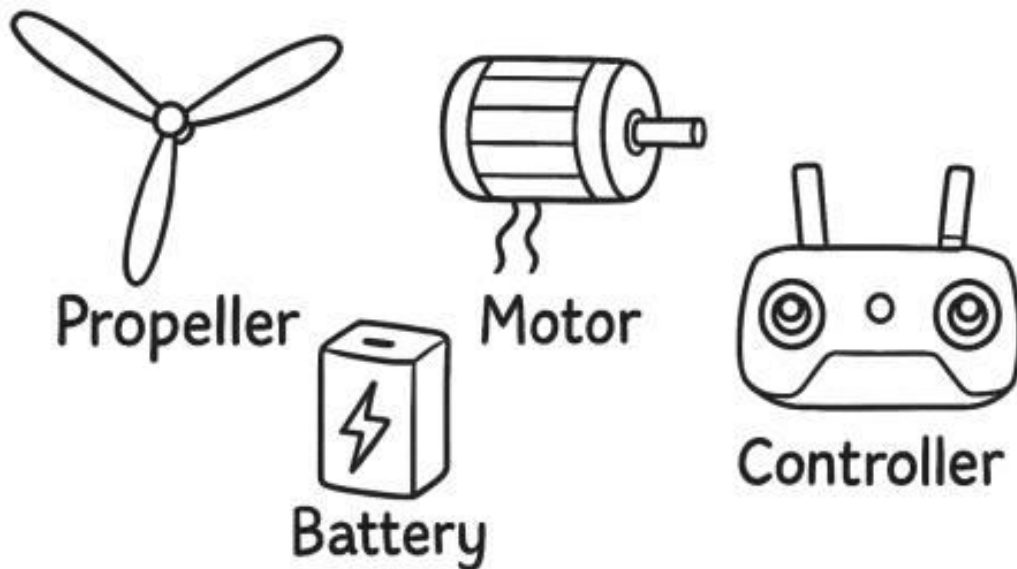

- **Propellers**

Propellers are like spinning wings. When they spin very fast, they push air downwards, which lifts the drone up into the sky. Without propellers, the drone wouldn't be able to fly.

- **Motors**

Motors are the machines inside the drone that make the propellers spin. Each propeller is connected to a motor. These motors must work perfectly together to move the drone forward, backward, or turn.

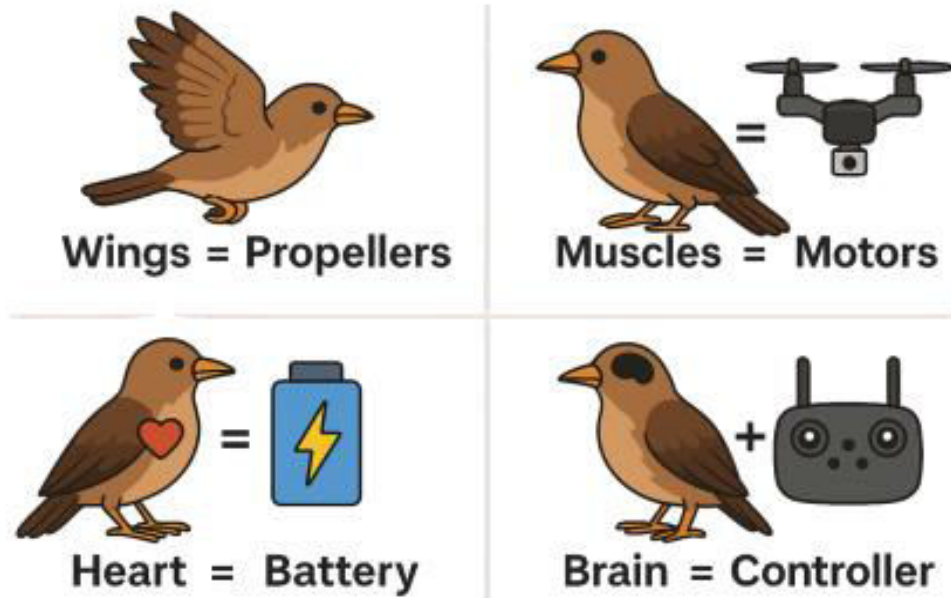

- **Battery**

The battery is the power source of the drone— just like how your toys need batteries to work. It gives energy to the motors, sensors, and all parts of the drone. The stronger the battery, the longer the drone can fly.

- **Controller**

The controller is like a remote control. You hold it in your hands and use it to tell the drone where to go—up, down, left, right, or even hover in one place. It sends signals to the drone wirelessly.

## ACTIVITY 6

### Scratch Programming – Jumping Panda Game

#### Aim:

Make a Panda jump to avoid obstacles and score points.

#### STEP 1: Open Scratch

1. Go to <https://scratch.mit.edu>
2. Click **Create**
3. Delete the cat sprite (Right click → Delete)

#### STEP 2: Add Panda Sprite

1. Click **Choose a Sprite**
2. Search **Panda**
3. Click on Panda

#### STEP 3: Add Background

1. Click **Choose a Backdrop**
2. Select **Blue Sky or Forest**
3. Click OK

#### STEP 4: Add Obstacle (Rock)

1. Click **Choose a Sprite**
2. Search **Rock**
3. Select it
4. Place it on the right side

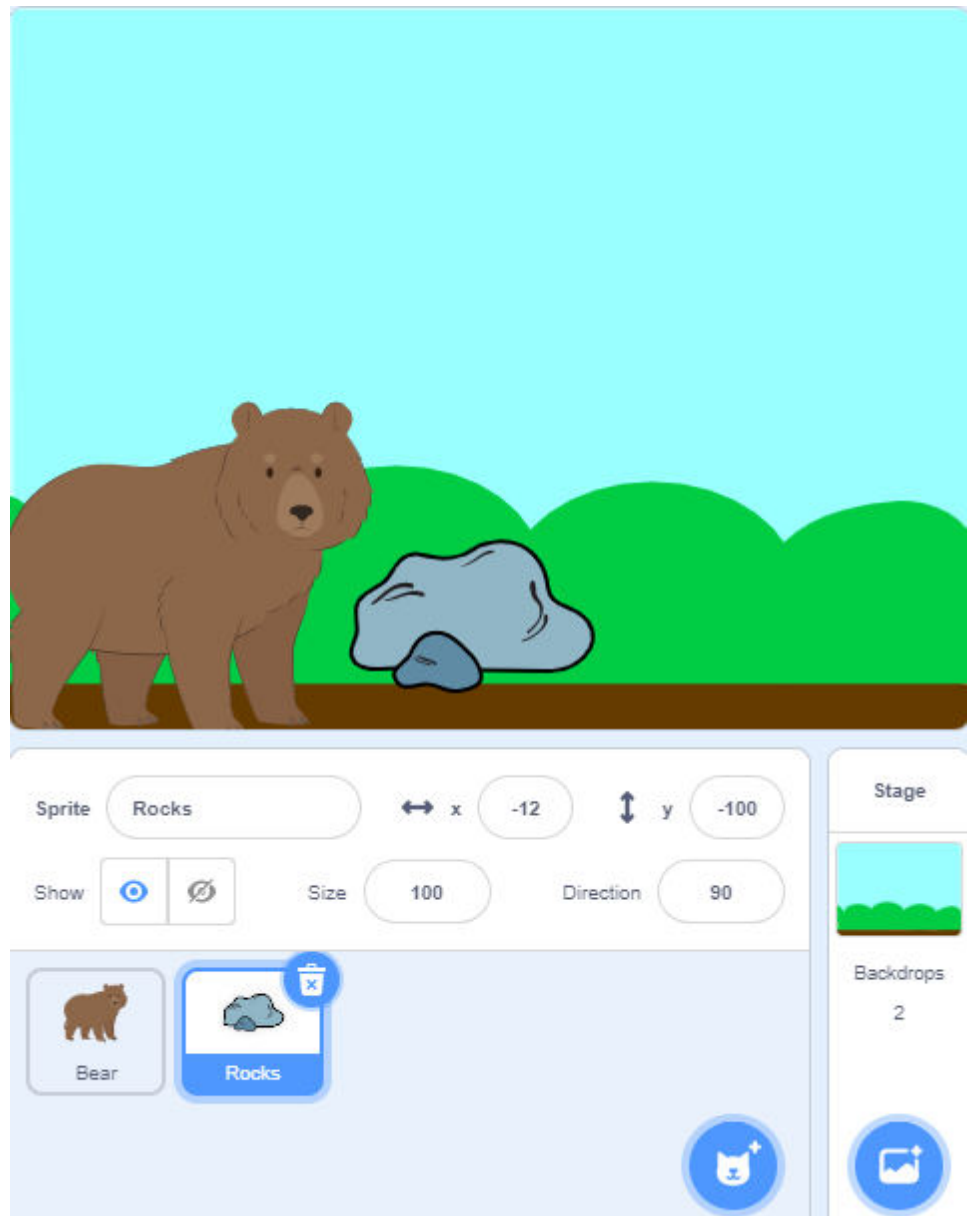

### STEP 5: Code for Panda Jump

Click on **Panda sprite**

Go to **Code** tab

#### Add These Blocks:

When game starts AND Make Panda Jump when Space key pressed:

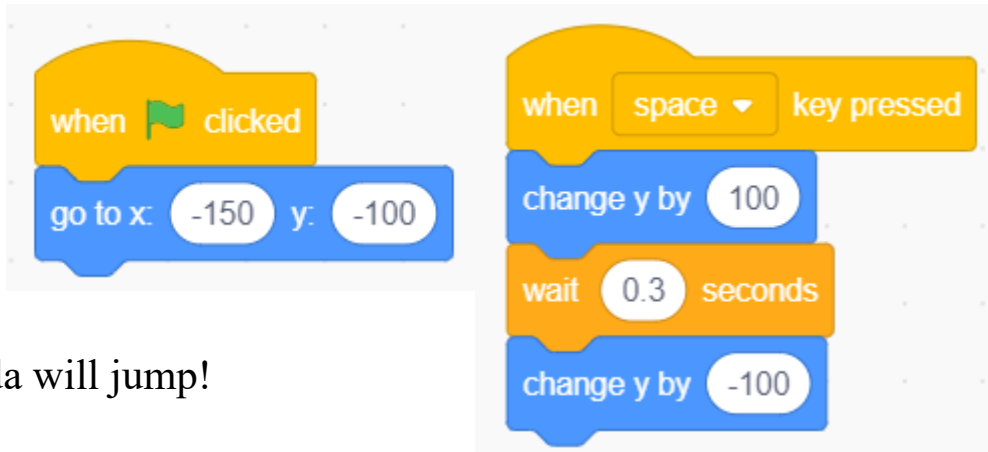

Now Panda will jump!

### STEP 6: Code for Moving Rock

Click on **Rock sprite**

Add:

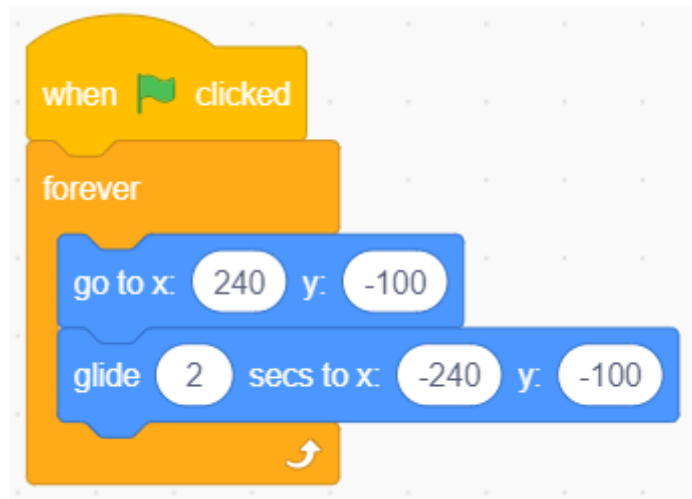

Rock will keep moving from right to left.

**STEP 7: Game over Condition**

Click on **Panda** sprite

Add:

**STEP 8: Add Score**

1. Click **Variables**
2. Click **Make a Variable**
3. Name it → Score

Add this in Rock sprite:

Score increases each time rock passes.

**Final Output**

- ✓ Panda jumps
- ✓ Rock moves
- ✓ Score increases
- ✓ Game Over message appears

**Learning Concepts**

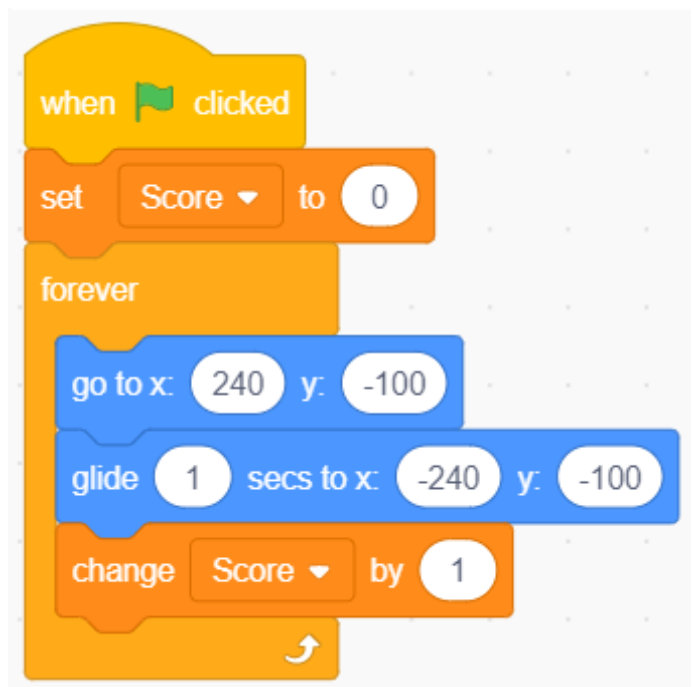

Concept	What Students Learn
Sprite	Game character
Backdrop	Background
Motion Blocks	Move sprite
Event Blocks	When green flag clicked
Control Blocks	If, Forever
Variables	Score counting